



The latest 'must have' for the contemporary home. With unparalleled innovation, function and build quality. The Rolaway Underground Hose is NOW AVAILABLE. Please see specs sheet for prices.

## The Rolaway Underground Hose System can make using a hose so much easier.

Easily installed anywhere, the unit stores 20 metres of hose completely out of sight and is auto retractable. The casing is designed to be set in concrete, into paving or to go straight into the ground near your tap. All components are stainless steel or high strength UV protected nylon. The Rolaway hose is an Australian made product built to last, combining the best of good design, ergonomics and function.

FREE DELIVERY to major regional areas in Australia. Place your order by phoning Free call 1800 765 2929.



**Phone: 1800 ROLAWAY**  
7 6 5 2 9 2 9

Phone: +61-2 6653 6773

Email: [info@rolaway.com](mailto:info@rolaway.com)

**[www.rolaway.com](http://www.rolaway.com)**



ABN 97 237 9586

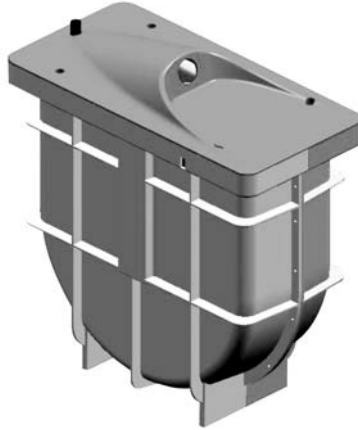

## CONCEALED RETRACTABLE HOSE REEL 20m

### FEATURES

Out of sight

Stainless steel power spring

Stainless steel entry ferrel

Hose stop

20 metre hose

Hose and fittings

Tough casing

Easy installation

Built for the harshest conditions

Eliminates wear

Prevents hose from winding back too far

Auto lock hose at any length

Pre assembled

Install anywhere including concrete

### PRODUCT SPECIFICATIONS

Dimensions

500 x 500 x 250

Hose length

20 metres

Working pressure

150 psi

Full flow water swivel

Yes

Double "O" rings

Yes

Fittings included

Yes

Hose type

PVC

Weight

10.5kg

Warranty

3 years

Trade Price

\$254 + GST

Retail

\$349

**Phone: 1800 ROLAWAY**  
7 6 5 2 9 2 9

Phone: +61-2 6653 6773

**Email: [info@rolaway.com](mailto:info@rolaway.com)**

**[www.rolaway.com](http://www.rolaway.com)**

